

### 841 BULKHEAD FITTING WITH #6 RETURN

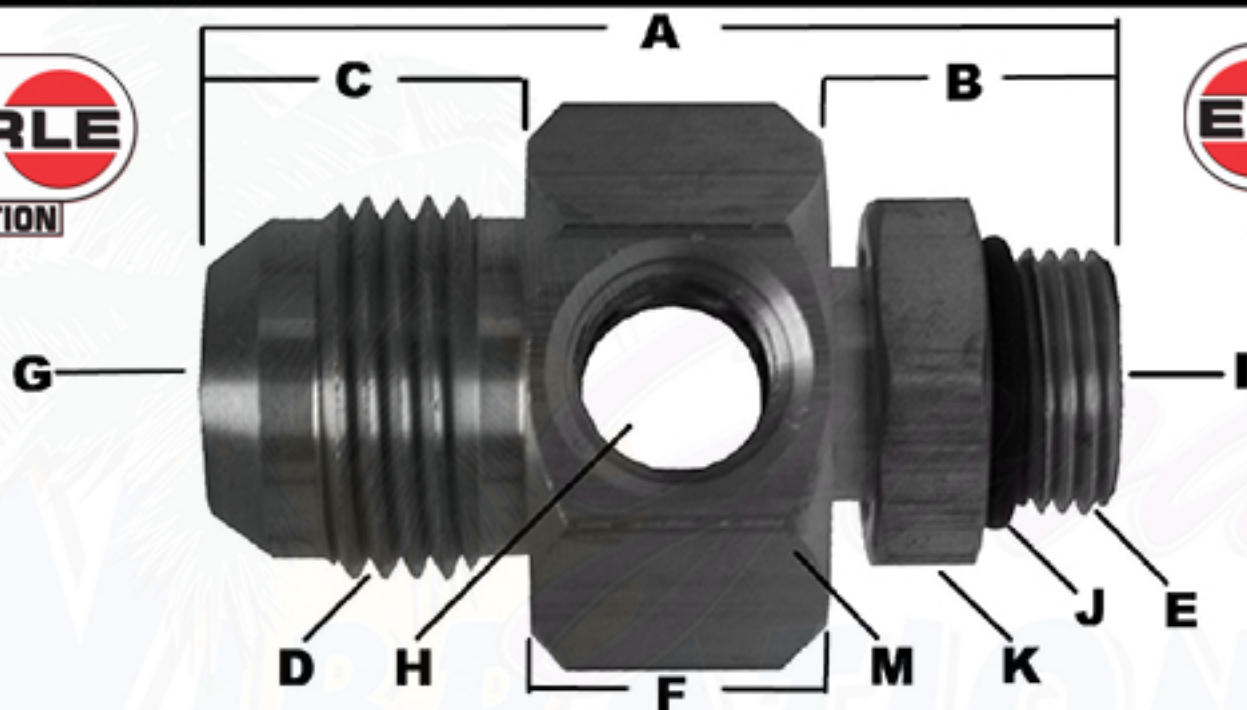

| PART#      | (A)LENGTH | (B)LENGTH | (C)LENGTH | (D) THRD  | (E)THRD   | (F)LENGTH | (G)HOLE | (H) HOLE | (I)HOLE | (J)O-RING | (K)NUT | M(HEX) |
|------------|-----------|-----------|-----------|-----------|-----------|-----------|---------|----------|---------|-----------|--------|--------|
| 841-8-8B   | 2.288     | .800      | .688      | 3/4-16    | 3/4-16    | .800      | .450    | 9/16-18  | .450    | #8        | 924-8  | 1 3/8  |
| 841-10-8B  | 2.376     | .800      | .776      | 7/8-14    | 3/4-16    | .800      | .450    | 9/16-18  | .484    | #8        | 924-8  | 1 3/8  |
| 841-10-10B | 2.358     | .800      | .785      | 7/8-14    | 7/8-14    | .800      | .485    | 9/16-18  | .485    | #10       | 924-10 | 1 3/8  |
| 841-12-8B  | 2.288     | .800      | .864      | 1 1/16-12 | 3/4-16    | .800      | .609    | 9/19-18  | .485    | #8        | 924-8  | 1 3/8  |
| 841-12-10B | 2.464     | .800      | .864      | 1 1/16-12 | 7/8-14    | .800      | .609    | 9/16-18  | .609    | #10       | 924-10 | 1 3/8  |
| 841-12-12B | 2.839     | 1.05      | .864      | 1 1/16-12 | 1 1/16-12 | .925      | .608    | 9/16-18  | .608    | #12       | 924-12 | 1 3/8  |
| 841-16-12B | 2.886     | 1.05      | .911      | 1 5/16-12 | 1 1/16-12 | .925      | .844    | 9/16-18  | .743    | #12       | 924-12 | 1 3/8  |
| 841-16-16B | 2.886     | 1.05      | .911      | 1 5/16-12 | 1 5/16-12 | .925      | .844    | 9/16-18  | .844    | #16       | 924-16 | 1 5/8  |
| 841-20-12B | 2.933     | 1.05      | .953      | 1 5/8-12  | 1 1/16-12 | .925      | 1.075   | 9/16-18  | .733    | #12       | 924-12 | 1 5/8  |

### 841 BULKHEAD SLIP-ON STYLE FITTING WITH #6 RETURN

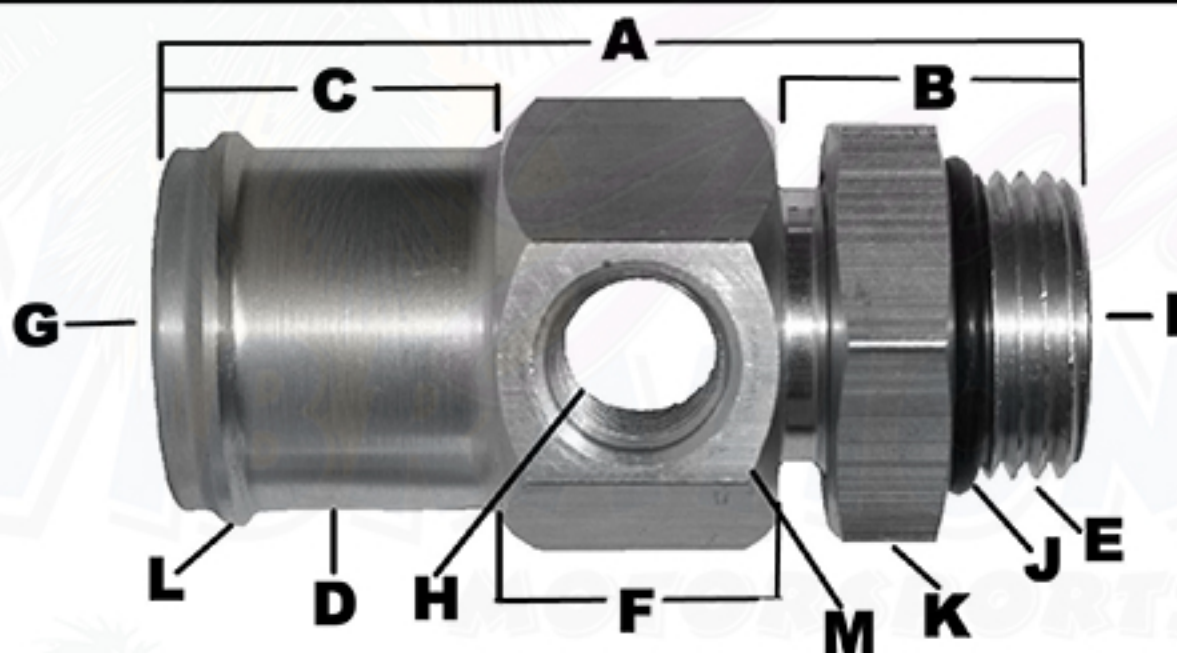

| PART#   | A(LENGTH) | B(LENGTH) | C(LENGTH) | D(DIA) | E(THRD)   | F(LENGTH) | G(HOLE) | H(HOLE) | I(HOLE) | J(O-RING) | K(NUT) | L(BEAD) | M(HEX) |
|---------|-----------|-----------|-----------|--------|-----------|-----------|---------|---------|---------|-----------|--------|---------|--------|
| 841-12B | 3.175     | 1.05      | 1.2       | 1.25   | 1 1/16-12 | .925      | 1.018   | 9/16-18 | .750    | #12       | 624-12 | 1.365   | 1 3/8  |
| 841-16B | 3.175     | 1.05      | 1.2       | 1.25   | 1 5/16-12 | .925      | 1.018   | 9/16-18 | .872    | #16       | 924-16 | 1.365   | 1 5/8  |

### 841 SLIP-ON STYLE FITTING

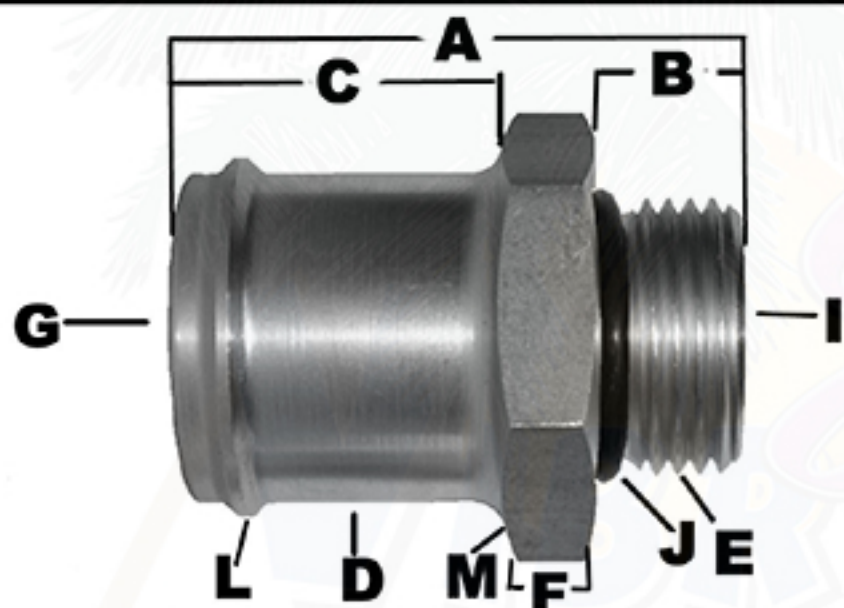

| PART#  | A(LENGTH) | B(LENGTH) | C(LENGTH) | D(DIA) | E(THRD)   | F(LENGTH) | G(HOLE) | H(HOLE) | I(HOLE) | J(O-RING) | L(BEAD) | M(HEX) |
|--------|-----------|-----------|-----------|--------|-----------|-----------|---------|---------|---------|-----------|---------|--------|
| 841-12 | 2.10      | 1.34      | 1.2       | 1.25   | 1 1/16-12 | .35       | 1.018   | .75     |         | #12       | 1.365   | 1 3/8  |
| 841-16 | 2.10      | .55       | 1.2       | 1.25   | 1 5/16-12 | .35       | 1.018   | 1.018   |         | #16       | 1.365   | 1 1/2  |